

EXTERIOR

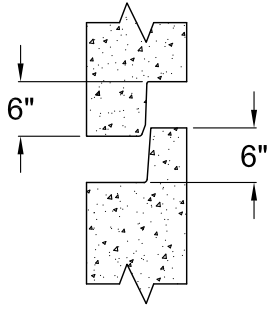

JOINT DETAIL

STD. OPENINGS AVAILABLE
26" I.D.
24" x 25"
24" x 30"
24" x 36"

OPENING SIZE SHAPE AND LOCATION AS REQUIRED

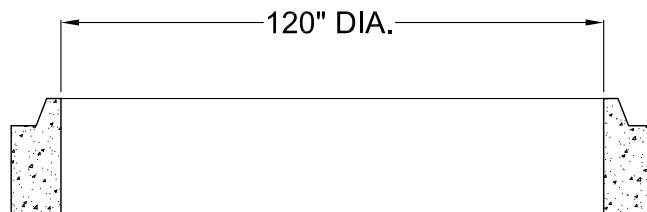
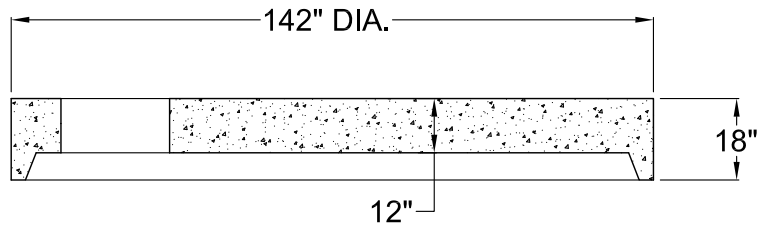
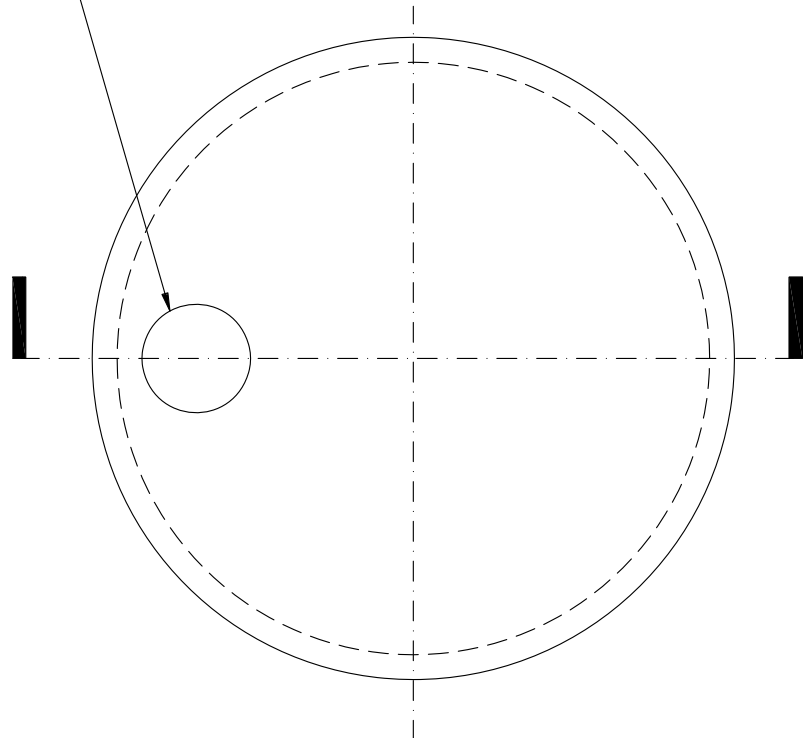

NOTES

1. ALL UNITS MEET ASTM C-478 FOR PRECAST SECTIONS.
2. ALL UNITS MEET ASTM A-82, A-496, A-185, AND A-497 FOR REINFORCEMENT.
3. ALL UNITS MEET AASHTO M 199M.
4. BUILT IN ACCORDANCE WITH WISCONSIN STANDARD SPECIFICATIONS CHAPTER 3.5.0 AND 3.6.0.
5. BUILT IN ACCORDANCE WITH IDOT AND WDOT STANDARD SPECIFICATIONS.
6. COATINGS OPTIONAL AS REQUIRED.

STANDARD PRECAST 120" DIA. FLAT TOP SECTION



8011 GREEN BAY ROAD
KENOSHA, WI. 53142

PH: (262) 694-3166
FAX: (262) 694-9185

DRN BY: DM	DATE 07/25/07	DWG NO.	REV
CHK'D BY:	DATE	SCALE NTS	SHEET OF