

EXTERIOR

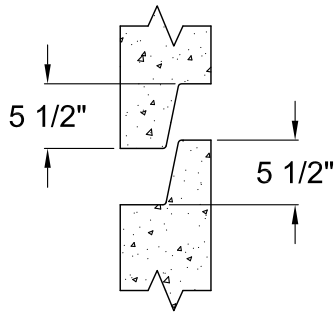

JOINT DETAIL

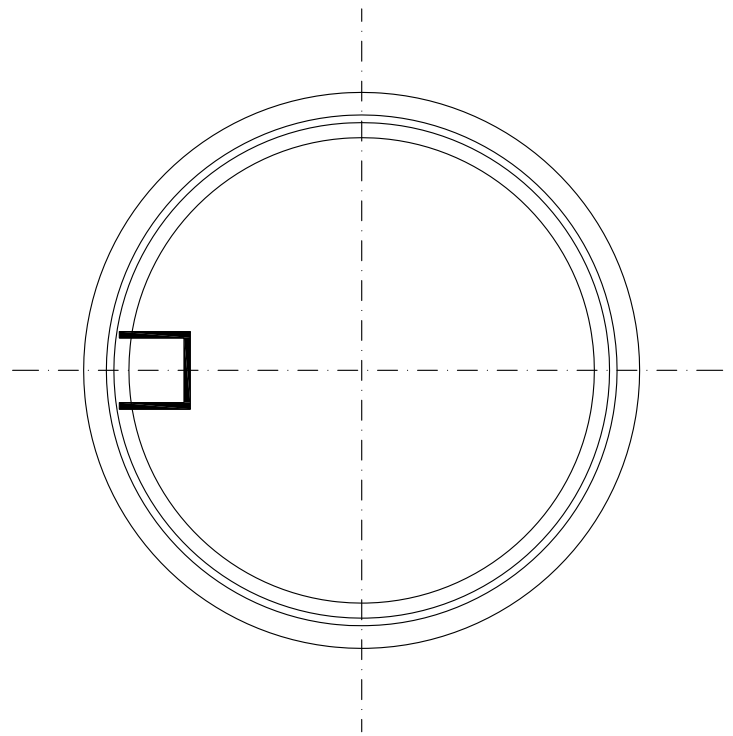

TYPICAL HEIGHTS ARE:  
 24", 30", 32", 36", 40", 48", 60", 66", 72",  
 78", 84"

B = 6" TYP.  
 B = 8" AS REQUIRED

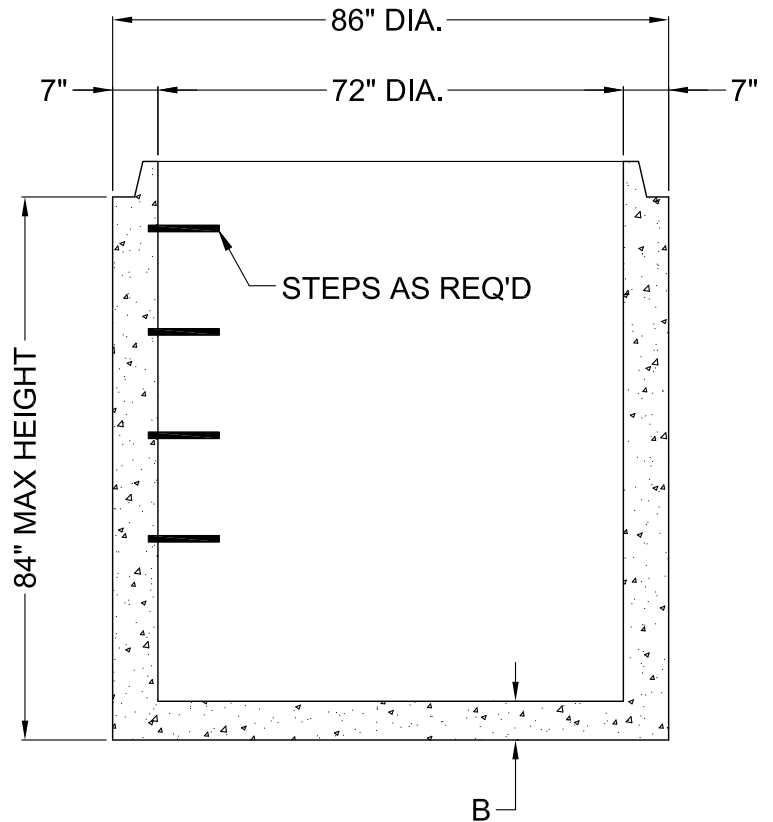

**NOTES**

1. CONCRETE TO BE MINIMUM 4500 PSI AT 28 DAYS.
2. ALL CONCRETE CATCH BASINS AND MANHOLES ARE MANUFACTURED WITH WELDED STEEL WIRE FABRIC CONFORMING TO ASTM A-185.
3. ALL MANHOLES ARE MANUFACTURED TO COMPLY WITH ASTM DESIGNATION C-478 AND ILLINOIS DEPARTMENT OF TRANSPORTATION HIGHWAY STANDARDS.

**72" DIA. BASE SECTION**



P.O. BOX 157  
 HAZELCREST, IL 60420  
 TEL: (708) 339-7765  
 FAX: (708) 338-3706

DRN BY: <b>DM</b>	DATE <b>08/31/07</b>	DWG NO.	REV
CHK'D BY:	DATE	SCALE <b>NTS</b>	SHEET OF