

EXTERIOR

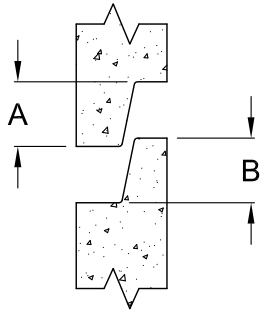

JOINT DETAIL

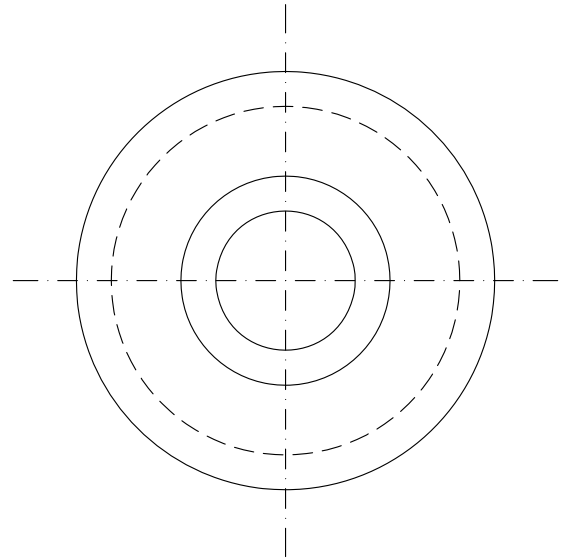

Inside Diameter	Outside Diameter	Wall Thickness	Groove Height	Tongue Height	Typical Height of Concentric Cone Section
ID	OD	WALL	A	B	H
48"	58"	5"	2 3/4"	2 5/8"	36", 52"
60"	72"	6"	2 3/4"	2 3/4"	36", 48"

NOTES

1. CONCRETE TO BE MINIMUM 4500 PSI AT 28 DAYS.
2. ALL CONCRETE CATCH BASINS AND MANHOLES ARE MANUFACTURED WITH WELDED STEEL WIRE FABRIC CONFORMING TO ASTM A-185.
3. ALL MANHOLES ARE MANUFACTURED TO COMPLY WITH ASTM DESIGNATION C-478 AND ILLINOIS DEPARTMENT OF TRANSPORTATION HIGHWAY STANDARDS.

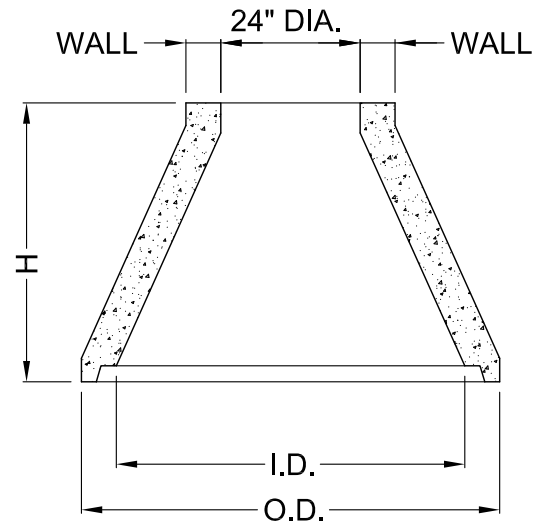

CONCENTRIC CONE SECTIONS



P.O. BOX 157
 HAZELCREST, IL 60420
 TEL: (708) 339-7765
 FAX: (708) 338-3706

DRN BY: DM	DATE 08/31/07	DWG NO.	REV
CHK'D BY:	DATE	SCALE NTS	SHEET OF