

EXTERIOR

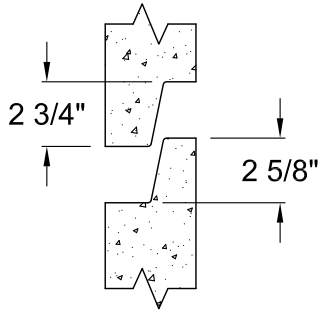

JOINT DETAIL

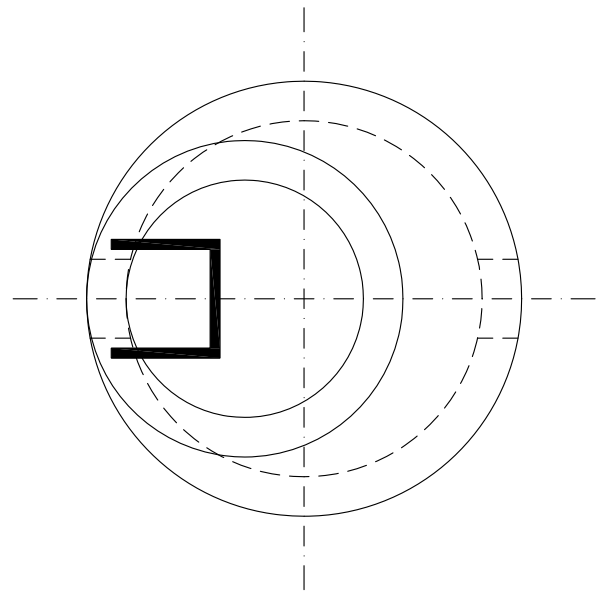

B = 6" TYP. OR AS REQ'D

CONC. SLAB
AS REQ'D

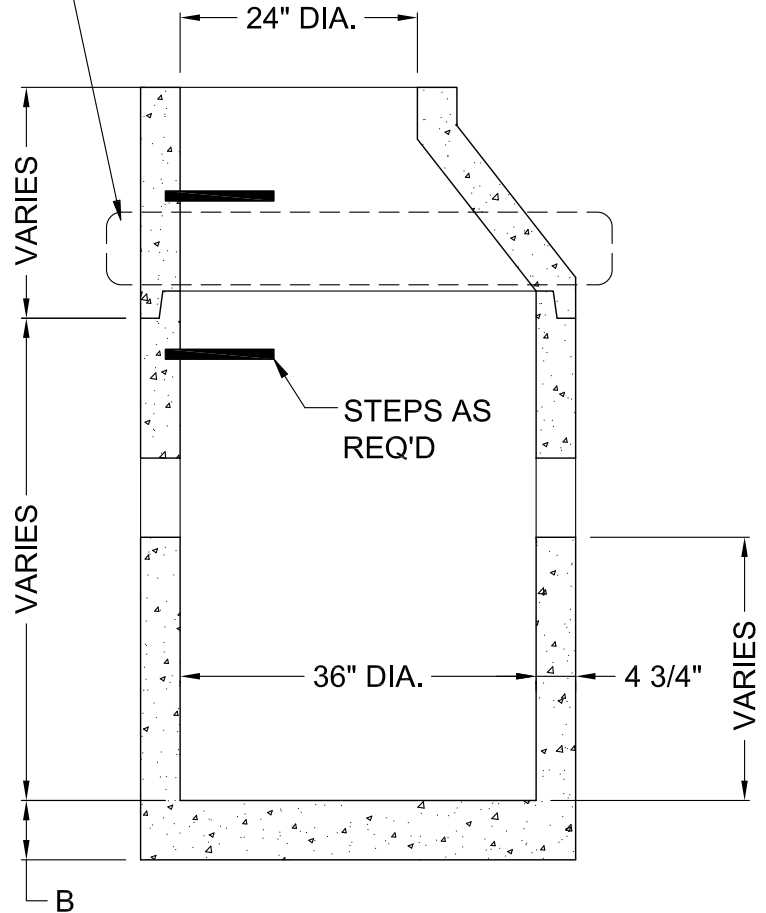

NOTES

1. CONCRETE TO BE MINIMUM 4500 PSI AT 28 DAYS.
2. ALL CONCRETE CATCH BASINS AND MANHOLES ARE MANUFACTURED WITH WELDED STEEL WIRE FABRIC CONFORMING TO ASTM A-185.
3. ALL MANHOLES ARE MANUFACTURED TO COMPLY WITH ASTM DESIGNATION C-478 AND ILLINOIS DEPARTMENT OF TRANSPORTATION HIGHWAY STANDARDS.

36" DIA. CATCH BASIN



P.O. BOX 157
HAZELCREST, IL 60420
TEL: (708) 339-7765
FAX: (708) 338-3706

DRN BY: DM	DATE 08/31/07	DWG NO.	REV
CHK'D BY:	DATE	SCALE NTS	SHEET OF